



Coil Spring Kit
Part No. 705401
84-97 2WD & 4WD Jeep XJ Cherokee
84-90 2WD & 4WD Jeep Wagoneer
86-92 2WD & 4WD Jeep Comanche

NOTE: Please read these instructions thoroughly before starting the installation.

Check the parts lists against the contents. Make sure you have all listed parts.

This installation is a two man operation. Have a friend handy.

This suspension lift is not overly difficult to install, but it is very time consuming. Budget at least one day for the installation.

Complete all installation steps and install all parts supplied in the kit. Failure to do so may result in damage or failure of related vehicle component parts.

PARTS LIST

<u>PART NO.</u>	<u>QUANTITY</u>	<u>DESCRIPTION</u>
735401	2	Coils
711127	2	Lower Trailing Arms
780313	1	Black Diamond Decal
B/D00461	1	Warning Decal
 <u>Parts Pack - 719041</u>		
711175	4	Trailing Arm Bushing Sleeve
712136	8	Poly Trailing Arm Bushings
14GF90	4	Zirc Fitting

1. Jack up front of vehicle. Check all wires and hoses for clearance, especially on the passenger's side behind the differential. Place jack stands under frame rails and lower vehicle onto jack stands. Leave floor jack directly under the differential, but without weight of vehicle on it. Remove wheels and shocks.

2. Remove the stock lower trailing arms and set aside the stock bolts and nuts for reinstallation. Remove nut and washer from sway bar, located in front of both coil springs. It may be necessary on some vehicles to remove front drive shaft, although on most vehicles, this should not need to be done. Under the passenger's side coil spring, locate and remove bolt and nut holding the track arm in place. Let floor jack (positioned under the differential) down far enough to remove stock coil springs. Remove bolt in clip which holds coils in place. Remove springs.
3. Install new Black Diamond coil springs (the clip that holds coil spring in place may have to be notched or bent before bolt can be reinstalled). Raise differential with floor jack. Put new poly bushings, steel sleeves, and grease zerks into new lower trailing arms and install arms on vehicle, using stock bolts and nuts. Do not completely tighten bolts yet.
4. Locate the original track arm mounting hole on the passenger side of the axle. Measure 3/4" from the center of the stock hole on a horizontal line toward the driver's side of the vehicle. Center punch and drill a 3/8" hole through the front of the bracket only. Repeat the measurement on the back side of the bracket and using the front hole as a guide, drill a 3/8" hole through the back side of the bracket. Position the free end of the track arm between the new holes and attach using the stock bolt. Locate the opening between the rear of the tracking arm bracket and the front axle, which is approximately 1.5" below the coil spring (the opening faces the driver's side of the vehicle.) Insert the square nut into the opening, align it with the stock bolt and tighten. It may be beneficial to tape the nut to a screw driver to facilitate insertion.

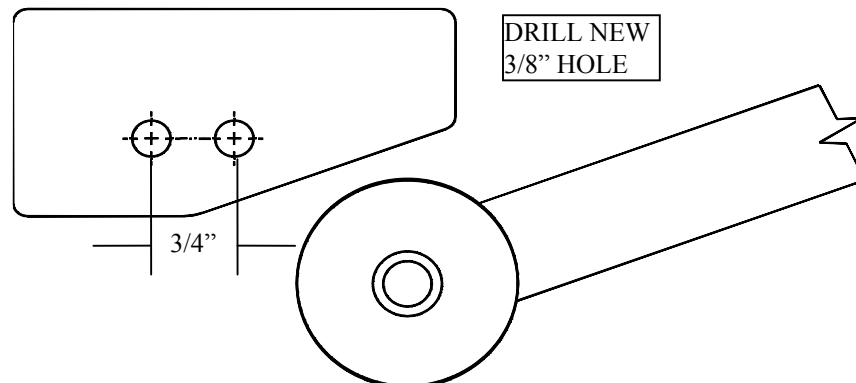

5. In front of both coil springs, reinstall sway bar with stock nuts and washers. Install new Black Diamond shocks.
6. Reinstall front drive shaft. Tighten all bolts affected during the installation. Put wheels back on, remove jack stands, and lower vehicle to the ground. Go back and check that all installation steps are completed. NOTE: Vehicle must have the front end aligned after the installation of the kit is completed.

IMPORTANT: Check the torque on all affected bolts and nuts after the first 100 miles, and after any off-road usage during the first 300 miles.

IMPORTANT PRODUCT USE INFORMATION

As a general rule, the taller a vehicle is, the easier it will roll over. Offset, as much as possible, what is lost in roll over resistance by increasing tire track width. In other words, go “wide” as you go “tall”. Many sportsmen remove their mud tires after winter / hunting season and install ones more appropriate for street driving; always use as wide a tire and wheel combination as possible to enhance vehicle stability.

We strongly recommend, because of roll over possibility, that the vehicle be equipped with a functional roll bar and cage system. Seat belts and shoulder harnesses should be worn at all times. Avoid situations where a side rollover may occur.

Generally, braking performances and capabilities are decreased when significantly larger / heavier tires and wheels are used. Take this into consideration while driving.

Do not add, alter, or fabricate any factory or aftermarket parts to increase vehicle height over the intended height of the Black Diamond product purchased. Mixing component brands is not recommended.

Most states have some type of law limiting vehicle height. The amount of lift allowed, and how the lift may be achieved, varies greatly. Several states offer exemptions for farm or commercially registered vehicles. It is the owner’s responsibility to check state and local laws to ensure that their vehicle will be in compliance.

Black Diamond makes no claims regarding lifting devices and excludes any and all implied claims. Black Diamond will not be responsible for any altered product or any improper installation or use of our products.

We will be happy to answer any questions concerning the design, function, and correct use of our products.

IMPORTANT MAINTENANCE INFORMATION

It is the ultimate buyer’s responsibility to have all bolts / nuts checked for tightness after the first 100 miles and then every 1000 miles. The steering, suspension and driveline systems, along with wheel alignment should be inspected by a qualified professional mechanic at least every 3000 miles.

NOTICE TO DEALER AND VEHICLE OWNER

Any vehicle equipped with a Black Diamond lifting device must have the enclosed “Warning to Driver” decal installed on the inside of the windshield or on the vehicle’s dash, within driver’s view. The “Warning to Driver” decal is to act as a constant safety reminder for whoever may be operating the vehicle. The WARRANTY IS VOID unless this decal is in place. **INSTALLING DEALER...** It is your responsibility to install warning decal and forward these installation instructions to the vehicle owner for review of warnings, product use and maintenance information. Replacement warning decals are available free upon request. These instructions are to be kept with the vehicle registration papers and owners manual for the service life of the vehicle.

BLACK DIAMOND LIMITED LIFETIME WARRANTY

Suspension products bearing the Black Diamond (Woods Ready Dist.) name are warranted for as long as the original purchaser owns the vehicle that the Woods Ready product was originally installed on. This warranty is non-transferable. Warranty covers only the product, no labor, time

loss, or freight incurred. Any product that has been abused, altered, incorrectly installed, or used in competition is not covered. Product finish, spring bushings, Polyurethane products, and normal wear is not covered. The Woods Ready product is subject to replacement or repair. No other warranties are expressed or implied. An authorized Black Diamond dealer must inspect the part in question and confirm that the "Warning to Driver" decal is properly displayed. A copy of the sales invoice is required for warranty consideration.

Black Diamond
274 Huey Lenard Loop Road
West Monroe, LA 71292
Toll Free: 866.680.6666
Fax: 318.397.3469
www.blackdiamondoffroad.com