

Black Diamond
274 Huey Lenard Loop Rd.
West Monroe, LA 71292
866/680-6666 toll free
318/397- 3470 sales / tech
318/397-2469 fax
www.blackdiamondoffroad.com



Installation Instructions and Parts list for

**Part No. 795122
3 1/2" Suspension System
For 1986-1996 Jeep YJ Wranglers**

NOTE:

Please read these instructions thoroughly before starting the installation.

Check the parts lists against the contents. Make sure you have all listed parts.

This suspension system should be installed by an experienced mechanic.

Suspension systems are complex to install and are very time consuming. Budget at least one day for the installation.

Complete all installation steps and install all parts supplied. Failure to do so may result in damage or failure of related vehicle component parts.

All information, illustrations, and specifications contained in this instruction manual are based on the latest product information available at the time of publication approval. The right is reserved to make changes at any time without notice.

CAUTION:

HEIGHT MODIFICATIONS MAY RAISE THE CENTER OF GRAVITY OF A VEHICLE. OFF ROAD OPERATION AND/OR HEIGHT MODIFICATION MAY INCREASE YOUR VEHICLE'S SUSCEPTIBILITY TO ROLL OVER. YOUR STATE MAY REGULATE HEIGHT MODIFICATIONS. PLEASE BE INFORMED OF THE LAW IN YOUR STATE. HEIGHT MODIFICATIONS MAY AFFECT REACTION, RIDE, HANDLING, AND THE WEAR RATE OF YOUR VEHICLE'S COMPONENTS. HAVE YOUR VEHICLE INSPECTED REGULARLY. HEIGHT MODIFICATIONS MAY REQUIRE OTHER ADJUSTMENTS TO YOUR VEHICLE. WARN RECOMMENDS INSTALLATION BY A PROFESSIONAL MECHANIC.

USE EXTREME CAUTION WHEN ENCOUNTERING CONDITIONS WHICH MAY CREATE VEHICLE LOSS OF BALANCE OR CONTROL. AVOID SHARP TURNS AND ABRUPT MANEUVERS WHICH MAY CAUSE A VEHICLE ROLL OVER. USE SEAT BELTS AND HARNESSSES. DON'T DRINK OR USE DRUGS AND DRIVE. TREAD LIGHTLY!

THE VEHICLE MUST BE ALIGNED BY A STATE APPROVED ALIGNMENT SHOP AFTER INSTALLATION OF THE SUSPENSION SYSTEM OR THE WARN WARRANTY WILL BE VOID.

PARTS LIST

10302	1/2" X 3-1/4" X 7" U-bolt	2
711160	Rear Track Bar Extension Bracket	1
711161	Bump Stop Extension Bracket	4
711162	Front Track Bar Extension Bracket	1
711166	Front Sway Bar Extension Link	2
719042	Hardware Kit	1
719043	Hardware Kit	1
77-1500	1/2" U-bolt Hardware Kit	2
782301	Poly Spring Eye Bushing Kit	2
780313	Black Diamond Decal	1
B/D00461	Warning To Driver Decal	1

719042

Part Number	Description	Qty
01-60416	5/8" Poly Sway Bar Bushing	4
700539	Rear Brake Line Extension	1
700547	2" Square Washer	1
711164	Beveled Transfer Case Spacer	6
711165	Beveled Transfer Case Washer	6
44-14-5040	Front Brake Line Bracket Right Side	1
44-13-5040	Front Brake Line Bracket Left Side	1
780069	Rear Track Bar Sleeve	1

719043

Part Number	Description	Qty
12C5NN	1/2" Nyloc Nut	3
12LW	1/2" Lock Washer	2
12MLN	12MM Nyloc Nut	1
12MX1.75X70CS	12mm X 70MM Bolt	2
12UW	1/2" UW Washer	8
12X3C8CS	1/2" X 3" Bolt	9
14X1C5CS	1/4" X 1" Bolt	2
14C5NN	1/4" Nyloc Nut	2
14SW	1/4" SW Washer	4
3693	1/4" Thick Spacer	2
711027	Cone Spacer	2
716UW	7/16" UW Washer	4
38C5NN	3/8" Nyloc Nut	2
38X1C5CS	3/8" X 1" Bolt	2
38SW	3/8" SW Washer	4
01-60451	5/8"O.D. X 1/2" I.D. Sway Bar Sleeve	2

782301

782303		
Part Number	Description	Qty
01-340	Poly Spring Eye Bushing Half	8
02-5342	Spring Eye Sleeve	2
03-157	Spring Eye Sleeve	2

77-1500		
Part Number	Description	Qty
1500	1/2" Fine Thread Nyloc Nut	8
1550	Extra Thick 1/2" U-bolt Washer	8

TOOLS RECOMMENDED FOR INSTALLATION

SAE combination wrench set
Metric combination wrench set
SAE socket set
Metric socket set
#40 torx head driver
#55 torx head driver
Torque Wrench

Hydraulic floor jack
Heavy duty jack stands
Pry bar
Ball joint separator
Dikes
Channel lock pliers
Dead blow hammer or equivalent
Small sledge hammer

FRONT SUSPENSION INSTALLATION

1. **Lift and support the vehicle, remove the wheels and shocks.** Park the vehicle on a flat level surface and apply the parking brake. With the vehicle still on the ground, break the lug nuts loose. Raise the front of the vehicle using a floor jack under the front axle. Place jack stands under both frame rails behind the front spring mount. Lower the vehicle onto the jack stands, but keep a slight amount of pressure under the front axle. Chock the rear tires to prevent movement. Remove the lug nuts and the tires and wheels. Remove the front shock absorbers.

FIGURE 1

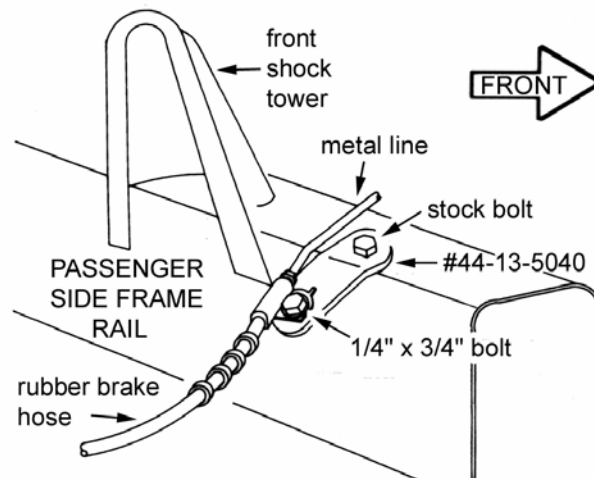

2. **Disconnect the factory brake lines from the frame, and install the new brake line extension brackets.** Locate the round head torx bit cap screws that hold the brake line brackets to the top of the frame. Remove these bolts from both sides. Install the new brake line extension brackets. Start on the driver's side. Locate the bend on the new extension bracket. Position the bend in the extension bracket so that it is aligned with the torx bolt hole (See figure 1). Thread the torx head bolt back into place and tighten to factory specifications. **(Note: Some bending of the metal portion of the brake line will be required to relocate the factory brake line. Be careful not to crimp or pinch the metal portion of the brake line. Bending the metal brake line around something with a round edge, such as, a ratchet extension or a piece of round stock will help prevent you from kinking the metal line. Also, it is better to make lots of little bends in the tubing rather than one large bend).** Now, gently bend the stock brake line until it's mounting hole is in line with the round hole and it's indexing tab is located in the square hole on the new bracket. Place one of the 1/4 inch SAE washers on one of the 1/4" x 3/4 inch hex head bolts. Now, insert the bolt down through the two holes. Place another of the 1/4" SAE washers on the protruding end of the bolt, thread the 1/4" all metal lock nut on and tighten (**Torque to 76 in lbs.**). This should locate the brake line so the rubber hose end is coming off the new bracket toward the rear of the vehicle (**Repeat the procedure to the other side**).

3. **Disassemble the stock sway bar and front track arm, and install the new front track arm extension bracket.** Remove the factory sway bar drop link upper mounting pins by pulling the cotter pin, removing the 3/4 inch lock nut and separating the pieces. You will need a ball joint separator to disconnect the top of the drop link. Remove the lower sway bar drop link mounts from the stud on the U-bolt plate (**Save the nut and washer that connect the drop link to the stud for reuse**). Unbolt the front track arm where it attaches to the boss on the axle housing (**Save lock nut for reuse**). You may want to tie the track arm up out of the way. Bolt in the new track arm extension bracket by placing the bottom of this "L" shaped bracket under the boss on the axle housing so that the large hole

fits over the machined end of the boss (See figure 2). At this point, take the 2 inch by 2 inch square plate washer and place it against the front of the track arm extension bracket making sure to line up the hole in the boss with the hole in the washer. Insert the M12 x 1.75 x 50mm bolt provided so the head of the bolt is toward the front of the vehicle. Install one of the 1/2 inch USS washers on the end of the bolt. Thread the factory lock nut on the bolt and tighten (**Torque to 125 ft-lbs.**).

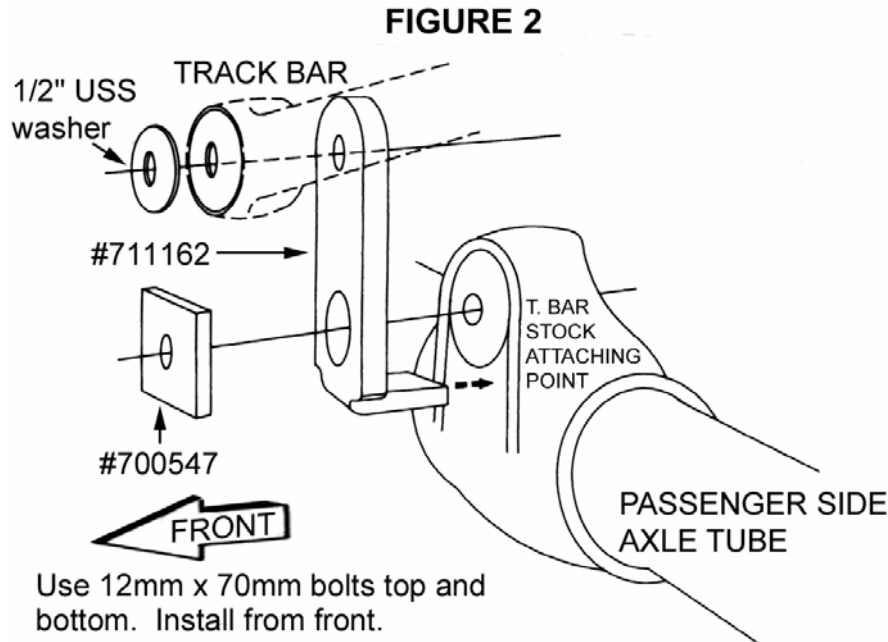

4. **Install the new front springs part number 780496. (CAUTION: BE CAREFUL WHENEVER HANDLING LEAF SPRINGS AS THEY STORE ENERGY EVEN WHEN UNLOADED).** In the passenger's side fender well, locate the plastic retaining the vacuum lines that go down to the differential against the fender. Using a pair of dikes, cut the end of the tab protruding into the wheel well. Push the tab back through the fender. This will allow the vacuum lines to travel downward when the differential is lowered. With the front axle supported by the floor jack, remove the front U-bolts. At this time, move the floor jack so that it is on the driver's side of the axle housing. Jack the housing up until it comes up off the driver's side spring approximately 1/2 inch. Loosen the driver's side front spring shackle upper nut and bolt. Remove the shackle's lower nut but leave the lower bolt in place (**Save the nut for reuse**). Remove the nut from the rear spring eye mounting bolt (**Save the nut for reuse**). Hold on to the stock spring and carefully pull one bolt out at a time. Remove the spring. Take the new front spring part # **780496** and coat the holes in the bushings and the bushing shoulders with a liberal amount of grease (**Preferably a lithium based grease**). This will help keep your suspension from squeaking. Install the spring so that the 1/2 inch ID bushings are to the front of the vehicle. Use the factory bolt and lock nut to secure the spring to the front shackle (**Do not tighten yet**). Place the end of the spring with 9/16 inch ID bushings up to the mounting bracket and check for fit. If necessary, spread open the bracket to accommodate the

spring. **Note the military or double wrap eye installs on the rear mounting bracket.** At this time, put the end of the spring with 9/16 inch ID bushings into the mount and secure with the factory bolt and lock nut (**Do not tighten yet**). Lower the front axle onto the spring. Move the floor jack to the passenger's side of the axle and jack the housing up until it is 1/2 inch off the spring (**Repeat the procedure to the passenger's side**).

5. **Attach the front axle to the new springs with the new U-bolts and the stock U-bolt plates.** There is a slight difference in length between the U-bolts that go over the front axle (**Longer**) and the ones that go over the rear axle (**Shorter**). With the front springs installed and the front axle resting on the new springs, Place one of the wider U-bolts over the front axle housing where the differential and the housing meet and one where the housing and the boss for the front track arm are connected. They should be just to the inside of the front springs. Place the narrower U-bolts over just the housing tube to the outboard side of the spring. Make sure the center pins of the springs are seated into the proper locating holes in the axle pad and that the relief holes in the U-bolt plates go over the nut and stud portion of the center pin. With the U-bolt plates over the ends of the U-bolts, install the 1/2" lock nuts onto the ends of the U-bolts. Place one of the new bump stop extension brackets on top of the axle on each side making sure the tab is under the outer U-bolt. Make sure bracket remains straight up, and tighten down the U-bolts (**Torque U-bolts from 65-85 ft-lbs.**). Tighten all the leaf spring bolts (**Torque both the top and bottom shackle bolts to 55-65 ft-lbs, and the rear pivot nut and bolt to 95-105 ft-lbs.**) being careful not to over tighten. The shackle should be allowed to move when pressure is applied. Install the front track arm to the upper mounting hole in the new track arm extension bracket using the 12mm x 70mm bolt, one of the USS washers, and one of the 12mm lock nuts. The head of the bolt should be toward the front of the vehicle and the washer and lock nut should be on the back of the extension bracket (**Do not tighten yet**).
6. **Install the new extended sway bar drop links.** Locate the four hourglass shaped bushings provided in the kit and insert them into the ends of the new drop links. Grease all the bushings in the new drop links. Insert one tube sleeve into one end of each of the new drop links. With the new drop links finished, move to the driver's side of the vehicle. Push the end of the new drop link without the sleeve in it over the stud on the U-bolt plate. Install the stock washer and lock nut onto the stud (**Do not tighten yet**). Connect the top of the new drop link by placing the cone shaped spacer into the end of the sway bar with the narrow part of the taper toward the center of the vehicle. Place the end of the new drop link with the sleeve in it against the out board end of the sway bar. Line up the hole in the cone spacer with the hole in the new drop link and secure using one of the 1/2" x 3 inch bolts, two of the 7/16 inch USS washers, one of the 1/2 inch lock washers and one of the 1/2" lock nuts (**Torque nut on U-bolt plate stud and sway bar/drop link nut and bolt to 60-85 ft-lbs. Repeat the procedure on the other side**).

7. **Install the new shocks.** Install the new shocks using the nut provided on the upper mount (**Torque to 76 ft.-lbs.**) and the factory nuts and bolts on the lower mount (**Torque to 44 ft.-lbs.**). Install the tires and wheels, and check the clearance between the tire and the brake line on both sides with the steering turned all the way to the right and then with it turned all the way to the left. Jack up the front-end, remove the jack stands from under the frame rails and lower the vehicle to the ground (**Torque the wheel lugs from 80-110 ft.-lbs.**).
8. **Lower the transfer case.** Place the floor jack under the transfer case skid plate/cross member, and jack up until slight pressure is applied. On the bottom of the skid plate, locate and loosen the three nuts in the center (**One of these nuts is on an insulator stud, so you will need to keep the stud from moving while you loosen the nut**). Remove and discard the six skid plate/cross member mounting bolts located along the frame rails (**Three on each side**). Lower the jack and skid plate approximately 6 inches. Insert the six transfer case concave tube spacers between the skid plate and the frame with the flat side of the spacers up toward the frame rail. Place one of the 1/2 inch USS washers and one of the beveled transfer case washers, respectively; on six of the 1/2" x 3 inch bolts provided (**Make sure the flat side of each beveled transfer case washer is against the 1/2 inch USS washer**). Install four of these bolts through the skid plate, in the four forward holes (**Two on each side**). These bolts should go through the skid plate/cross member, the beveled spacers and up into the frame rails, respectively (**See figure 3**). Thread these bolts into the holes several turns. Place one of the 1/2 inch ID x 1/4 inch thick round plate washers between the flat side of the transfer case concave tube spacers and the frame rail on the last two holes of the skid plate/cross member (**One on each side**). Install the two remaining bolts in these last two holes. Tighten all six bolts (**Torque to 65-80 ft.-lbs.**). Remove the floor jack and tighten the three nuts on the bottom in the center of the skid plate/cross member (**Torque the two nuts that go to the cushion mount from 30-50 ft.-lbs., and the nut that goes to the insulator stud from 20-35 ft.-lbs.**).

FIGURE 3

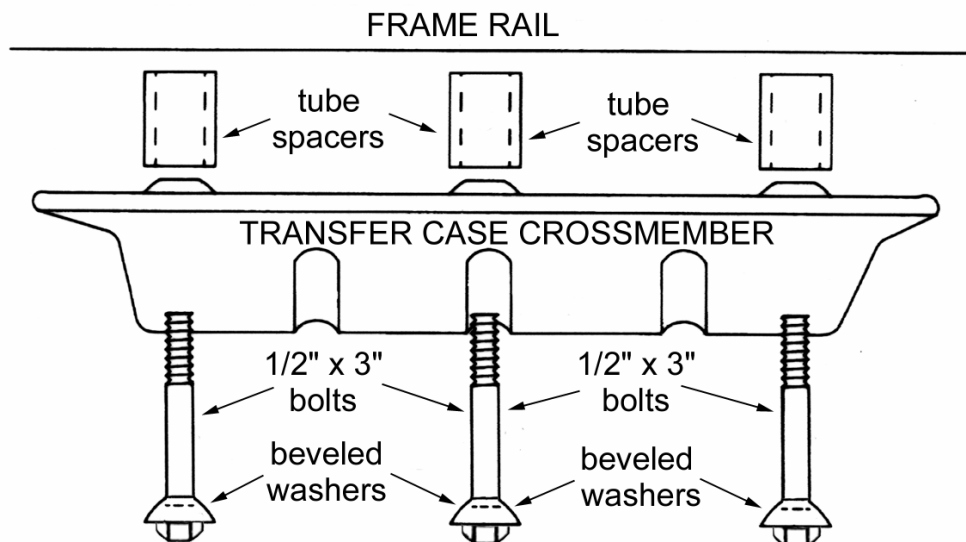

REAR SUSPENSION INSTALLATION

- 1. Raise the vehicle, remove the tires and wheels and remove the shocks.** With the vehicle still on the ground, break the lug nuts loose. Raise the rear of the vehicle using a floor jack placed under the rear axle. Place jack stands under both frame rails. Chock the front tires to prevent movement. Remove the rear tires and wheels. Remove the rear shocks.
- 2. Install the new rear brake line extension bracket.** Locate the factory rear brake line bracket on the inboard side of the frame near the driver's side rear wheel. Remove the horseshoe shaped clip that holds the brake line in place. Pull the brake line out of the bracket far enough to slip the metal portion of the brake line through the slot in the bracket. **(Note: Some bending of the metal portion of the brake line will be required to relocate the factory brake line. Be careful not to crimp or pinch the metal portion of the brake line. Bending the metal brake line around something with a round edge, such as, a ratchet extension or a piece of round stock will help prevent you from kinking the metal line. Also, it is better to make lots of little bends in the tubing rather than one large bend).** Locate the new "Z" shaped rear brake line extension bracket. The "Z" shaped bracket should be placed so that the end with the small hole is against the factory bracket, and the end with the large hole end is pointed away from the driver's side frame and downward. One of the 3/8 inch SAE washers should be put on one of the 3/8"-16 x 1 inch bolts. The bolt should be placed through the small hole in the new bracket and through the large hole in the factory bracket. The other 3/8 inch SAE washer is placed over the end of the bolt on the other side of the factory bracket in order to cover the large factory hole. Now, thread the 3/8"-16 lock nut onto the bolt and tighten **(Torque to 23 ft-lbs.)**.
- 3. Remove the rear track arm bracket.** Be very careful not to pull the drive shaft yoke out of the transfer case. Locate and unbolt the rear track arm where it attaches to the axle bracket. Save the factory bolt and lock nut for reuse and discard the U shaped bracket that is left over. Tie the track arm up out of the way at this time.
- 4. Install the new rear springs part number 780497 and attach the rear axle to the new springs with the new U-bolts and the stock U-bolt plates.. (CAUTION: BE CAREFUL WHENEVER HANDLING LEAF SPRINGS AS THEY STORE ENERGY EVEN WHEN UNLOADED).** With the rear axle supported by pressure from the floor jack, remove the rear U-bolts on the driver's side **(Note: Be careful not to pull the drive shaft yoke out of the transfer case)**. Move the floor jack so that it is on the driver's side of the axle housing. Jack the axle housing up until it comes up off the spring approximately **3 inches**. Loosen the driver's side rear spring shackle upper bolt and nut. Remove the shackle's lower nut but leave the bolt in place **(Save the nut for reuse)**. Remove the nut from the front spring eye mounting bolt **(Save the nut**

for reuse). Hold on to the stock spring and carefully pull one bolt out at a time (**Save the bolts for reuse**). Remove the spring (**Note: Once the U-bolts are removed and the axle housing is jacked up off the spring, you may have to push up on the factory spring so that the shackle will travel rearward far enough to get the shackle bolt past the gas tank**). Coat the holes in the new bushings and the bushing shoulders with a liberal amount of grease (**Preferably a lithium based grease**). Install the new spring part # **780497** by placing the end that has the 1/2 inch ID bushings between the rear shackle and secure using the factory bolt and lock nut (**Be sure that the head of the bolt is on the inboard side of the shackle. Do not tighten yet**). Put the end of the spring with the 9/16 inch ID bushings up to the mounting bracket and check for fit. If necessary, spread the bracket open in order to accommodate the spring. **Note the military or double wrap eye installs on the front mounting bracket**. At this time, put the end of the spring with 9/16 inch ID bushings into the mount and secure using the factory bolt and the factory lock nut (**Do not tighten yet**). Lower the rear axle onto the spring making sure the holes in the wedge and the axle pad go over the center pin in the spring. Attach the axle housing to the new springs using the new U-bolts. Make sure the center pins of the springs are seated into the proper indexing holes in the axle pads. Place two U-bolts over the axle housing in such a manner that there is one U-bolt on each side of the leaf spring. Place the U-bolt plate over the ends of the U-bolts making sure the relief hole in the U-bolt plate is over the nut and stud portion of the center pin. Thread the 1/2" lock nuts onto the ends of the U-bolts. Place one of the new bump stop extension brackets on top of the axle making sure the tab is under the outer U-bolt. Check that the bracket remains straight up, and tighten the U-bolts (**Torque U-bolts from 65-85 ft-lbs.**). Tighten all the leaf spring bolts (**Torque both the top and bottom shackle bolts to 55-65 ft-lbs. and the front pivot nut and bolt to 95-105 ft-lbs.**). The shackle should be allowed to move when pressure is applied. Move the floor jack to the passenger's side of the axle and jack the housing up until it is 3 inches off the spring (**Repeat the procedure to passenger's side. Note: You may find the passenger's side more difficult when you remove the shackle bolt. This is due to the location of the exhaust**).

- 5. Install the new rear track arm bracket.** Place the new track arm extension bracket into the center of the factory bracket, with the 3/8 inch round hole down and out board (**See figure 4**). Push the new bracket into the factory bracket until the bottom of the U is up against the inside edge of the driver's side wall of the factory bracket. Secure the two pieces using two 3/8 inch SAE washers, one 3/8" x 1 inch hex bolt and one 3/8" UNC lock nut (**Torque to 23 ft-lbs.**). Place one of the 1/2 inch USS washers on the remaining 1/2" x 3" inch hex bolt. Insert the 1/2 inch ID x 1.6 inch long spacer tube inside the new bracket in such a manner that it aligns with the hole in the factory bracket and the slotted holes in the new bracket. Insert the 1/2" x 3" hex bolt through the back of the factory bracket, the new bracket, the spacer tube and out through the front of the assembly. Place the remaining 1/2" USS washer over the portion of the bolt that is protruding toward the front of the vehicle and secure using the 1/2" lock nut (**Torque to 80 ft-lbs.**). Place the rear track arm into the middle of the new bracket and insert the factory

bolt through the back of the new bracket, the track arm and then through the front of the new bracket. Secure using the factory lock nut (**Do not tighten yet**).

6. **Install the new shocks, put the tires and wheels back on and lower the vehicle.** Install the new shocks (**Torque the upper and lower mounting nuts and bolts to 44 ft-lbs.**). With the new suspension at full extension, check the rear brake line, the emergency brake cable and the axle housing vent tube. The rear brake line should be close to completely extended but not taugt. If additional slack is required, bend the brake line extension bracket downward to provide relief. The emergency brake cable should also be extended but not strained. If additional slack is required, bend the factory cable hanger (**Located in the middle of the floor pan above the front of the rear differential**) downward and route the emergency brake cable along the rearward side of the muffler hangers instead of over them. The vent tube, like the other cables, needs to be checked for tightness. Install the tires and wheels. Place the floor jack under the center of the rear differential, jack the vehicle up off the jack stands, remove the jack stands and lower the vehicle to the ground (**Torque lug nuts from 80-110 ft-**

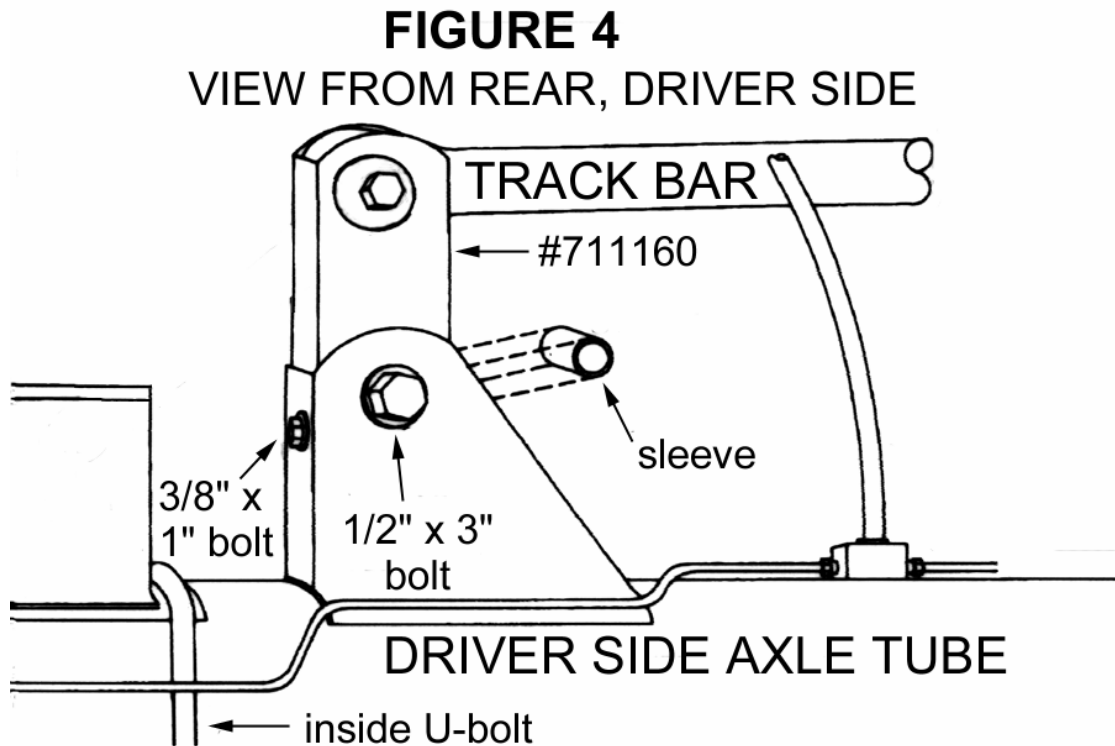

lbs.).

FINAL ADJUSTMENTS

Once the vehicle is sitting on a flat level surface, tighten the front track arm bolt and nut (**Torque to 74 ft-lbs.**). Also tighten the rear track arm bolt and nut (**Torque to 125 ft-lbs.**). At this time, get into your vehicle and check the shifting mechanism. If you have a manual transmission, make sure that you can shift into all gears without the shift lever hitting the floor pan. If the lever does contact the floor pan, trim away enough material to gain clearance (**Approximately 1/4 inch**) You may also find it necessary to move the center console rearward. If this is the case, unbolt the console, move it to the desired position, mark the holes and drill the floor pan so that the factory self tapping screws can be reused. If you have an automatic transmission, your engine should turn over in both park and neutral. If it will only turn over in one and not the other, or if it will turn over in any of the other positions, the neutral safety switch or the linkage must be adjusted. Have the necessary adjustment done by a certified Jeep technician. Check that all the installation steps have been completed, that all the parts provided have been used and that all nuts and bolts affected by the installation have been torqued.

CAUTION:

TO REDUCE THE CHANCE OF PERSONAL INJURY AND/OR PROPERTY DAMAGE, THE FOLLOWING INSTRUCTIONS MUST BE CAREFULLY OBSERVED:

PROPER INSTALLATION OR REPAIR IS IMPORTANT TO THE SAFETY OF THE INSTALLER AND THE SAFE, RELIABLE OPERATION OF THE MOTOR VEHICLE. IF PART REPLACEMENT IS NECESSARY, THE PART MUST BE REPLACED WITH ONE OF THE SAME PART NUMBER. DO NOT USE A REPLACEMENT PART OF LESSER QUALITY.

THE INSTALLATION PROCEDURES RECOMMENDED AND DETAILED IN THIS INSTRUCTION MANUAL ARE EFFECTIVE PROCEDURES FOR THE INSTALLATION OF THIS PRODUCT. SOME OF THESE PROCEDURES REQUIRE THE USE OF TOOLS SPECIFICALLY DESIGNED FOR THE PURPOSE MENTIONED.

ANYONE WHO INTENDS TO USE A REPLACEMENT PART, INSTALLATION PROCEDURE, OR TOOL THAT IS NOT RECOMMENDED BY BLACK DIAMOND, MUST FIRST DETERMINE THAT NEITHER HIS NOR HER SAFETY NOT THE SAFE OPERATION OF THE VEHICLE WILL BE JEOPARDIZED BY THE REPLACEMENT PART, INSTALLATION PROCEDURE OR TOOL SELECTED.

PLEASE NOTE THAT THESE INSTRUCTIONS CONTAIN SEVERAL CAUTION NOTICES WHICH MUST BE OBSERVED IN ORDER TO REDUCE THE RISK OF PERSONAL INJURY DURING INSTALLATION OR REPAIR, OR THE POSSIBILITY THAT IMPROPER INSTALLATION OR REPAIR MAY DAMAGE THE VEHICLE OR RENDER IT UNSAFE. ALSO NOTE THAT THESE CAUTIONS ARE NOT EXHAUSTIVE, BECAUSE IT IS IMPOSSIBLE TO WARN OF ALL THE POSSIBLE HAZARDOUS CONSEQUENCES THAT MIGHT RESULT FROM FAILURE TO FOLLOW THESE INSTRUCTIONS.

THE VEHICLE MUST HAVE A FRONT END ALIGNMENT DONE BY A STATE APPROVED SHOP OR THE BLACK DIAMOND WARRANTY WILL BE VOID! AFTER THE INITIAL 50-100 MILES AND EACH OFF ROAD USAGE, CHECK THE TORQUE ON ALL AFFECTED NUTS AND BOLTS AND INSPECT THE BRAKE LINES FOR ANY RUBBING, CHAFFING OR CRACKING! PERIODIC CHECKING OF THE U-BOLT NUTS FOR TIGHTNESS IS THE RESPONSIBILITY OF THE VEHICLE OWNER. DUE TO THE NEW RAISED HEIGHT OF THE VEHICLE, THE ALIGNMENT OF THE HEADLIGHTS SHOULD ALSO BE ADJUSTED, SO THAT ONCOMING TRAFFIC IS NOT AFFECTED.

IMPORTANT PRODUCT USE INFORMATION

As a general rule, the taller a vehicle is, the easier it will roll over. Offset, as much as possible, what is lost in roll over resistance by increasing tire track width. In other words, go "wide" as you go "tall". Many sportsmen remove their mud tires after winter / hunting season and install ones more appropriate for street driving; always use as wide a tire and wheel combination as possible to enhance vehicle stability.

We strongly recommend, because of roll over possibility, that the vehicle be equipped with a functional roll bar and cage system. Seat belts and shoulder harnesses should be worn at all times. Avoid situations where a side rollover may occur.

Generally, braking performances and capabilities are decreased when significantly larger / heavier tires and wheels are used. Take this into consideration while driving.

Do not add, alter, or fabricate any factory or aftermarket parts to increase vehicle height over the intended height of the Black Diamond product purchased. Mixing component brands is not recommended.

Most states have some type of law limiting vehicle height. The amount of lift allowed, and how the lift may be achieved, varies greatly. Several states offer exemptions for farm or commercially registered vehicles. It is the owner's responsibility to check state and local laws to ensure that their vehicle will be in compliance.

Black Diamond makes no claims regarding lifting devices and excludes any and all implied claims. Black Diamond will not be responsible for any altered product or any improper installation or use of our products.

We will be happy to answer any questions concerning the design, function, and correct use of our products.

IMPORTANT MAINTENANCE INFORMATION

It is the ultimate buyer's responsibility to have all bolts / nuts checked for tightness after the first 100 miles and then every 1000 miles. The steering, suspension and driveline systems, along with wheel alignment should be inspected by a qualified professional mechanic at least every 3000 miles.

NOTICE TO DEALER AND VEHICLE OWNER

Any vehicle equipped with a Black Diamond lifting device must have the enclosed "Warning to Driver" decal installed on the inside of the windshield or on the vehicle's dash, within driver's view. The "Warning to Driver" decal is to act as a constant safety reminder for whoever may be operating the vehicle. The WARRANTY IS VOID unless this decal is in place.

INSTALLING DEALER... It is your responsibility to install warning decal and forward these installation instructions to the vehicle owner for review of warnings, product use and maintenance information. Replacement warning decals are available free upon request. These instructions are to be kept with the vehicle registration papers and owners manual for the service life of the vehicle.

BLACK DIAMOND LIMITED LIFETIME WARRANTY

Suspension products bearing the Black Diamond are warranted for as long as the original purchaser owns the vehicle that the Black Diamond product was originally installed on. This warranty is non-transferable. Warranty covers only the product, no labor, time loss, or freight incurred. Any product that has been abused, altered, incorrectly installed, or used in competition is not covered. Product finish, spring bushings, Polyurethane products, and normal wear are not covered. The Woods Ready product is subject to replacement or repair. No other warranties are expressed or implied. An authorized Black Diamond dealer must inspect the part in question and confirm that the "Warning to Driver" decal is properly displayed. A copy of the sales invoice is required for warranty consideration.