



fBLACK DIAMOND, INC.
300 Huey Lenard Loop Rd.
West Monroe, Louisiana 71292
Phone: (318) 397-3000
Sales / Tech: 1-800-551-4955
FAX: (318) 397-3040
Web Site: www.blackdiamondoffroad.com

Black Diamond® 3" lift system for 2007 and newer JEEP WRANGLER (JK) 4WD

INSTALLATION INSTRUCTIONS

INTRODUCTION

Installation requires a professional mechanic. Prior to beginning, inspect the vehicles steering, driveline, and brake systems, paying close attention to the suspension link arms and bushings, anti-sway bars and bushings, tie rod ends, pitman arm, ball joints and wheel bearings. Also check the steering sector-to-frame and all suspension-to-frame attaching points for stress cracks. The overall vehicle must be in excellent working condition; repair or replace all worn parts.

Read instructions several times before starting. Be sure you have all needed parts and know where they install. Read each step completely as you go.

NOTES:

- **Prior to beginning the installation, check all parts and hardware in the box with the parts list below. If you find a packaging error, contact Black Diamond® directly. Do not contact the dealer where the system was originally purchased. You will need the control number from each box when calling; this number is located at the bottom of the part number label and to the right of the bar code.**
- A precision steering alignment, including the centering of the steering wheel, is required in order for the vehicle's Electronic Stability Program to function properly. Using "all laser" alignment equipment is recommended.
- 33" – 35" tires can be used without fender trimming.
- Maximum tire width = 12.5"; Minimum tire diameter = 17"; Wheel width 8-9"; Minimum backspacing = 4.5"; Maximum backspacing = 4.75"
- Stock wheels can be used with 33" tires. If 35" tires are used with stock wheels, 1.5" wheel spacers are required for tires to clear frame rails and allow full turning radius.
- Replacement shock absorbers are required and sold separately.
- Front end realignment is necessary.
- An arrow on diagrams indicates which direction is toward the front of the vehicle.
- A foot-pound torque reading is given in parenthesis () after each appropriate fastener.
- Do not fabricate any components to gain additional suspension height.
- Prior to drilling or cutting, check behind the surface being worked on for any wires, lines, or hoses that could be damaged.
- After drilling, file smooth any burrs and sharp edges.
- Paint or undercoat all exposed metal surfaces.

- Prior to attaching components, be sure all mating surfaces are free of grit, grease, excessive undercoating, etc.
- A factory service manual should be on hand for reference.
- Use the check-off box “☐” found at each step to help you keep your place. Two “☐☐” denotes that one check-off box is for the driver side and one is for the passenger side.

PARTS LIST ... The part number is stamped into each part or printed on an adhesive label. Identify each part and place the appropriate mounting hardware with it.

PART NO.	DESCRIPTION <small>(Qty.- if more than one)</small>	NEW ATTACHING HARDWARE <small>(Qty.)</small>	BAG #
780121.....	(2) front coil spring		
780123.....	(2) rear coil spring four-door models only		
OR			
780122	(2) rear coil spring two-door models only		
06-5702	(2) front compression dampener		
07-5702	(2) rear compression dampener		
55-01-5704	front track bar	(2) 9/16" x 3" bolt..... (4) 9/16" SAE washer (2) 9/16" Stover nut (1) 1" OD x 1-9/16" sleeve (2) bushing half (1) 1/4" grease fitting (1) Heim joint end (2) Heim spacer (1) 3/4" jam nut	77-5704C
* 55-19-5704	front brake hose relocation..... bracket, driver side	(1) 1/4" x 3/4" bolt..... (1) 1/4" SAE washer (1) 1/4" Nyloc nut	77-5704B
* 55-20-5704	front brake hose relocation..... bracket, passenger side	(1) 1/4" x 3/4" bolt (1) 1/4" SAE washer (1) 1/4" Nyloc nut	
* 55-21-5704	rear brake hose relocation bracket, driver side	(1) 1/4" x 3/4" bolt..... (1) 1/4" SAE washer (1) 1/4" Nyloc nut (1) 1/4" x 1/2" self-tapping bolt (1) Adel line clamp	77-5704B
* 55-22-5704	rear brake hose relocation bracket, passenger side	(1) 1/4" x 3/4" bolt..... (1) 1/4" SAE washer (1) 1/4" Nyloc nut (1) 1/4" x 1/2" self-tapping bolt (1) Adel line clamp	77-5704B

PART NO.	DESCRIPTION (Qty.- if more than one)	NEW ATTACHING HARDWARE (Qty.)	BAG #
* Brake hose / line relocation brackets are not used if longer, optional Superlift® Bulletproof brake hoses are used.			
55-02-5704	rear track bar bracket	(1) 9/16" x 3-1/4" bolt (1) 9/16" SAE washer (1) 9/16" Stover nut (1) 1/2" x 1" bolt (1) 1/2" SAE washer (1) 1/2" Stover nut (1) 1-1/4" OD x 1-5/8" sleeve	700611
06-5704	(2) cam bolt assembly		700611
12-5704	(2) rear stabilizer bar link	(2) hardware pack (2) hourglass bushing (2) 5/8" OD x 1-7/16" sleeve	700611
55-13-5704	(2) front stabilizer bar link washer		700611
55-25-5704	rear track bar brace, weld-on		
700612	(2) compression travel pad spacer, front	(2) 5/16" x 1-3/4" self-tapping bolt	700611
	E-brake cable relocation hardware	(2) 1/4" x 1/2" self-tapping bolt	700611
Part numbers depend on type ordered		(4) shock absorber w/ boot (2) hardware pack, cable tie	
B/D00461	decals, "Warning To Driver"		
780313	decals, Black Diamond®		

FRONT DISASSEMBLY

NOTE: Save all factory components and hardware for reuse, unless noted.

1) PREPARE VEHICLE...

Place vehicle in neutral. Raise front of vehicle with a jack and secure a jack stand beneath each frame rail, behind the front / lower link arms. Ease the frame down onto the stands, place transmission in low gear or "park", and chock rear tires. Remove front tires.

Position a jack so that it supports, but does not raise, the front axle.

2) TRACK BAR... Remove the bolts securing the front track bar-to-axle and frame. The bar and hardware will not be re-used.

3) STABILIZER BAR LINKS AND SHOCK ABSORBERS...

- Remove and discard the front stabilizer bar links.
- Remove and discard the shock absorbers.

4) BRAKE HOSES, WIRING, AXLE VENT HOSE...

If optional extended length Bulletproof brake hoses are being used, these relocation brackets are not required. Install Bulletproof hoses now per separate instructions.

If Bulletproof hoses are not being used, detach the factory brake hose bracket (one per side) at the frame. This bracket holds the connection between the rubber brake hose and the metal brake line.

The following steps provide adequate wiring / vent hose length to accommodate additional suspension extension travel:

On each side, a clip attaches the ABS wire loom to the top / inboard side of the shock tower. Remove and discard the clip.

The upper end of the axle vent hose is clamped to the driver side frame rail. Leave the hose attached to frame; simply pull down approximately 3" of hose.

On Rubicon models, the wiring loom for the locking differential is attached to the axle-to-frame upper link. Remove and discard the clip.

5) DRIVESHAFT...

Unbolt the front driveshaft at the front axle then tie it up and out of the way. Do not let the shaft "hang"; this risks pinching / damaging the grease boot at the transfer case end.

6) COIL SPRINGS AND COMPRESSION TRAVEL DAMPENERS...

Loosen, but do not remove, the upper and lower link arm bolts at the axle and frame.

Lower the axle enough to facilitate removing the front coil springs.

Pry the factory compression dampeners out of their mounting cups and discard.

FRONT ASSEMBLY

NOTE: If replacement axle-to-frame links (purchased separately) are being used, install now per separate instructions. Cam bolts (step 7) are not required with Black Diamond's replacement links; caster alignment is corrected by the links' longer length.

7) CAM BOLTS... [DIAGRAM 1]

One side at a time, remove the bolt securing the lower link arm-to-axle then remove the rear knock-outs that change the opening from a square hole to a slotted hole. A special tool is available for this, or use a die grinder with a small cutting wheel.

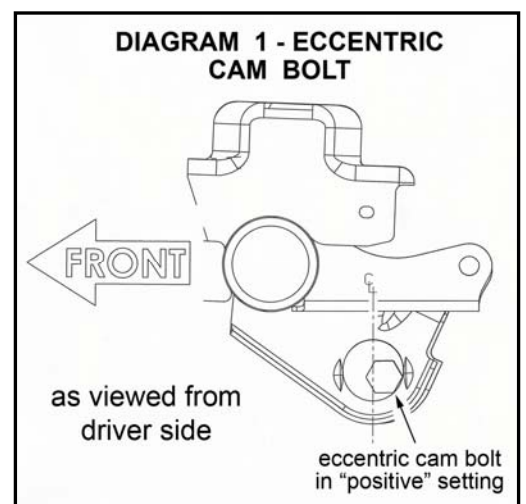

Reconnect lower link-arms-to axle using the supplied cam bolts (#700611), installed from the outside. Rotate the cams to their “most positive” setting, so that the front axle is shifted as far forward as possible (the bolt head will be in its most rearward position). Snug-up the bolts; do not fully tighten at this time.

8) COMPRESSION TRAVEL DAMPENERS AND COMPRESSION TRAVEL DAMPENER PAD SPACERS...

Press the Black Diamond® compression dampeners (#06-5702) into the factory mounting cups. If necessary, the axle can be raised to assist in seating the stops.

[DIAGRAM 2] One compression travel dampener pad spacer (#700612) installs on top of each coil spring's lower seat. The otherwise round seat has a flat edge that faces outboard. Locate center for the hole to be drilled by using the dimensions in Diagram 2; note that the compression pad spacer is installed slightly outboard of seat center. Drill at the marked location using a 17/64” bit.

Thread the just-drilled hole using the supplied 5/16” x 1-3/4” self-tapping bolt then remove the bolt.
NOTE: The compression pad spacer must first be inserted into the coil spring before it is bolted to the coil seat; see next step.

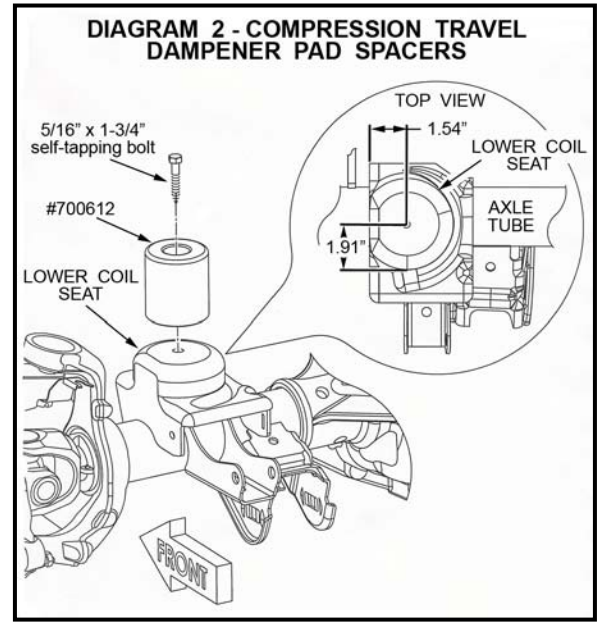

9) COIL SPRINGS, SHOCK ABSORBERS (ordered separately)...

Perform step 9 one side at a time.

Be sure the factory rubber isolators are still in place inside the coil spring tower.

Insert the compression travel dampener pad spacer into the bottom of the coil spring and hold it in place. Insert the upper end of the coil spring into the tower first, followed by the lower seat. Be sure that the coils are indexed so they seat properly then raise the axle enough to hold the coil springs in place.

Position the compression travel dampener pad spacer onto the lower spring seat then secure it using the supplied 5/16” x 1-3/4” self-tapping bolt and tighten (200 in-lb).

[DIAGRAM 3] Install shock absorber. Tighten the upper hardware until bushings swell slightly. Install the lower shock bolts, but do not tighten at this time. Apply shock decals. After the shock absorber installation is complete, the jack can be lowered and relocated to allow installation on the opposite side.

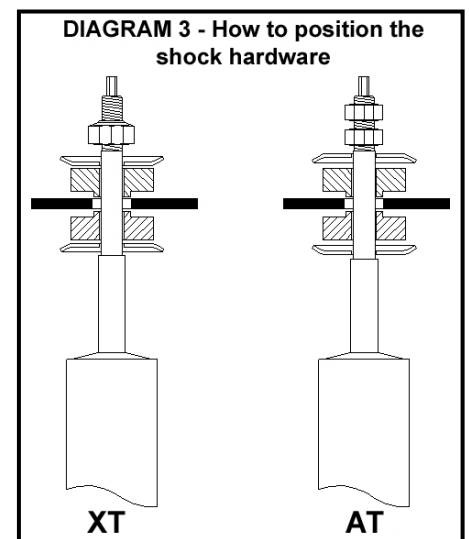

10) TRACK BAR...

Thoroughly coat the supplied Urethane bushing halves and the 1” OD x 1-9/16” sleeve with a light, Silicone or Lithium based grease. Insert bushings / sleeve into the track bar eye. Install the

supplied grease fitting.

- ❑ Thread the supplied jam nut onto the Black Diamond® Heim joint and loosely thread the Heim into the bar. Set the overall length of the bar to 33-1/8" measured between eye centers. This will serve as a baseline prior to final adjustment. Do not tighten the jam nut at this time.
- ❑ Place one supplied Heim spacer on each side of the Heim end then position the assembly in the track bar mount on the axle. Attach using the supplied 9/16" x 3" bolt, SAE washers, and Stover nut; place a washer on both the bolt head and nut side. Do not tighten at this time.
- ❑ Connect upper end of bar-to-frame using the supplied 9/16" x 3" bolt, SAE washers, and Stover nut; place a washer on both the bolt head and nut side. Do not tighten at this time.

NOTE: Final track bar adjustment and tightening are performed in later steps.

NOTE: The track bar must be greased during each oil change / service.

11) BRAKE HOSES... [DIAGRAM 4]

NOTE: If optional Bulletproof brake hoses are being used, these relocation brackets are not required.

- ❑❑ Attach the appropriate brake hose relocation bracket (#55-19-5704 driver side; #55-20-5704 passenger side) to the factory brake hose, as shown. Use the supplied 1/4" x 3/4" bolt, facing outward. The washer is used on the bolt head side. Install the supplied Nyloc nut and tighten (76 in-lb).
- ❑❑ Carefully re-form the metal brake line then bolt the Black Diamond® relocation bracket to the frame at the factory location. Use factory hardware (76 in-lb).

12) STABILIZER BAR LINKS...

- ❑❑ Remove the factory rear stabilizer bar-to-axle links, and install them on the front of the vehicle. Attach the swivel (upper) end of the stabilizer bar link-to-bar body (the stud faces inboard) then secure using factory hardware (66).

- ❑❑ Attach the lower (eye ring) end of stabilizer bar link-to-axle. The eye ring seats against the inboard side of the mounting tab. The factory mounting bolt installs from the outboard side through the mounting tab then through the eye ring. Position one supplied .5" ID x 1.6" OD x .1875" thick washer onto the factory mounting bolt, install factory nut then tighten (75). Remove the factory rear stabilizer bar-to-axle links, and use them on the front. Attach the swivel end of the link to the bar body and secure using factory hardware (75).

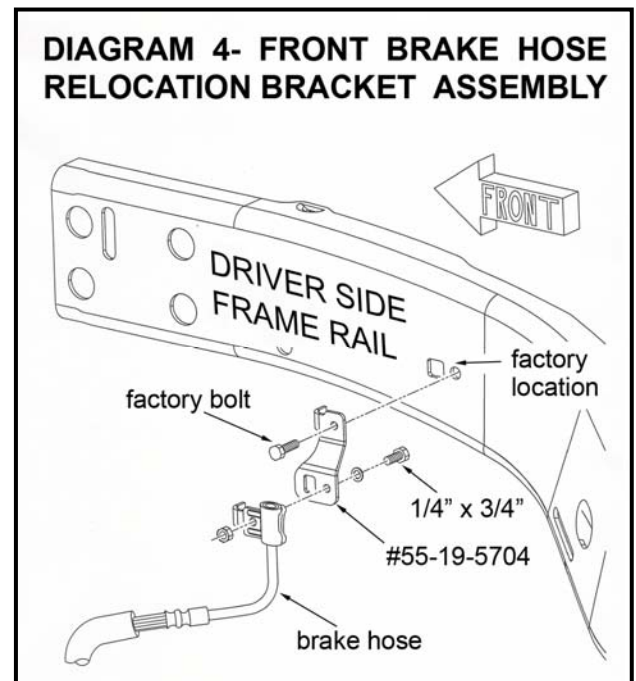

13) FRONT CROSSMEMBER, AUTOMATIC TRANSMISSION MODEL ONLY... [DIAGRAM 5]

Most models with automatic transmissions are equipped with a transmission pan skid plate / crossmember assembly. The forward lip of the crossmember must be trimmed to create adequate clearance between it and the driveshaft during full extension travel. The trimming process can be accomplished without removing the crossmember. Check for adequate clearance with suspension a full extension (with the front axle "hanging"). Excessive trimming weakens the crossmember.

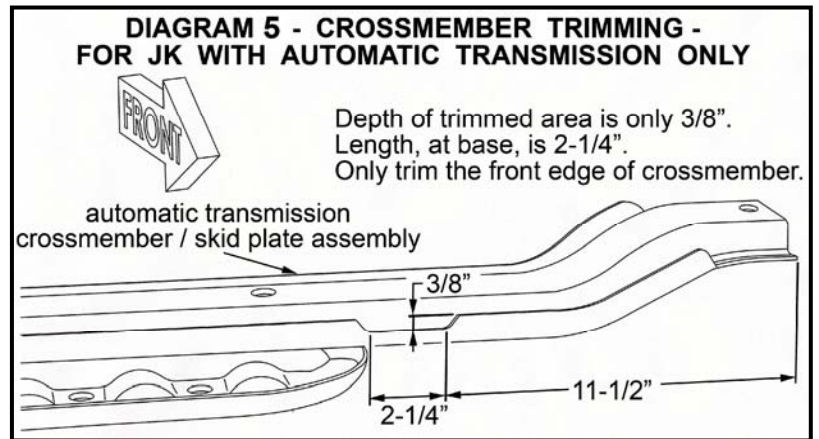

14) FRONT DRIVESHAFT...

Connect the front driveshaft-to-axle using the factory hardware (81).

15) TIRES / WHEELS... [DIAGRAM 6]

Tighten the lug nuts (115) in the sequence shown.

WARNING: When the tires / wheels are installed, always check for and remove any corrosion, dirt, or foreign material on the wheel mounting surface, or anything that contacts the wheel mounting surface (hub, rotor, etc.). Installing wheels without the proper metal-to-metal contact at the wheel mounting surfaces can cause the lug nuts to loosen and the wheel to come off while the vehicle is in motion.

WARNING: Retighten lug nuts at 500 miles after any wheel change, or anytime the lug nuts are loosened. Failure to do so could cause wheels to come off while vehicle is in motion.

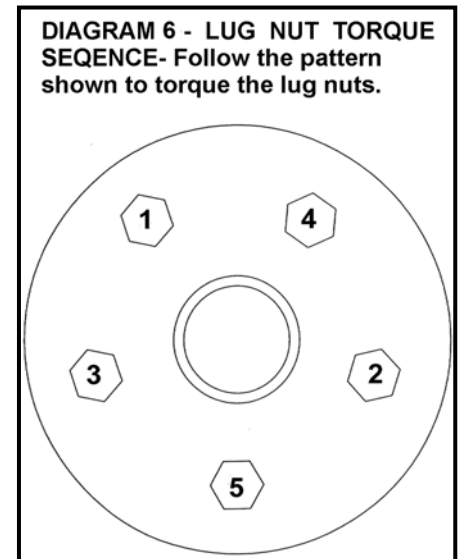

16) INITIAL CLEARANCE CHECK, FRONT...

With the vehicle still on jack stands, and the suspension "hanging" at full extension travel, cycle steering lock-to-lock and check all components for proper operation and clearances. Pay special attention to the clearance between the tires / wheels and brake hoses, wiring, driveshaft-to-crossmember, etc.

Lower vehicle to the floor. Final tightening and adjustments to the front suspension will take place once rear lift is completed.

REAR DISASSEMBLY

17) PREPARE VEHICLE...

Place vehicle in neutral. Raise rear of vehicle with a jack and secure a jack stand beneath each frame rail, just ahead of the rear / lower link arms. Ease the frame down onto the stands, place transmission in low gear or "park", and chock front tires. Remove rear tires.

Position a jack so that it supports, but does not raise, the rear axle.

18) TRACK BAR AND LINK ARMS...

Disconnect the factory track bar from both its axle and frame attachment points. Set the bar aside.

Loosen, do not remove, the bolts securing both lower link arms to the axle and frame.

Loosen, do not remove, the bolts securing both upper link arms to the axle and frame.

19) BRAKE HOSES... If optional extended length Bulletproof brake hoses are being used, The supplied relocation brackets are not required. Install Bulletproof hoses now per separate instructions.

If Bulletproof hoses are not used, detach the factory brake hose bracket at the frame. This bracket holds the connection between the rubber brake hose and the metal brake line.

20) WHEEL SPEED SENSOR WIRES...

On each side, at the driver side upper link arm frame mount, two clips retain the wheel speed sensor wires. Disconnect the forward-most clip from the frame mount.

21) SHOCK ABSORBERS AND COMPRESSION TRAVEL DAMPENERS...

Remove and discard the factory rear shock absorbers.

Pry the factory compression dampeners from their mounting cups and discard.

22) PARKING BRAKE CABLE BRACKETS, DIFFERENTIAL WIRING...

Locate the wire bracket securing the parking brake cables to the bottom of the rear floorboard, above and slightly in front of the rear axle. Unbolt the wire bracket.

On Rubicon models, a wiring loom for the locking differential clips to a bracket bolted to the top of the differential cover. Un-clip the wiring loom then either remove the bracket, or use a mallet to flatten-out the clip side of the bracket. Failure to do so will cause the wiring loom to snag on the bracket during suspension articulation.

23) COIL SPRINGS... Lower the axle just enough to facilitate removing the coil springs.

CAUTION: The driveshaft has a rubber boot on the transfer case end. If the axle is lowered too much, boot bind / damage may occur.

REAR ASSEMBLY

24) COMPRESSION TRAVEL DAMPENERS... Press the supplied rear compression dampeners (#07-5702) into the factory mounting cups on the frame. If necessary, the axle can be raised to help press the stops into place.

25) COIL SPRINGS... Install the new coil springs. Rotate the coils so that they seat properly in the coil buckets then raise the axle enough to seat the springs.

NOTE: If replacement axle-to-frame links (purchased separately) are being used, install now per separate instructions.

26) INITIAL TRACK BAR BRACKET AND BRACE FITMENT...

NOTE: If optional Black Diamond® track bar bracket with integrated bolt-on brace is being used, instead of the supplied weld-on brace, install now per separate instructions.

❑ Inspect the factory track bar mount-to-axle tube welds for tears and stress cracks, and repair as needed.

❑ [DIAGRAM 7] Position Black Diamond® rear track bar bracket (#55-02-5704) over the factory track bar mount, as shown. Insert the supplied 9/16" x 3-1/4" bolt through the Black Diamond® bracket and factory mount; do not install the 1-1/4" OD x 1-5/8" spacer sleeve yet. Only snug-up the bolt; do not fully tighten.

❑ [DIAGRAM 8] Position the Black Diamond® track bar bracket so that its track bar eye hole is vertically aligned with the factory mount's track bar eye hole. Securely clamp the Black Diamond® bracket-to-factory mount. Remove the 9/16" bolt then using the Black Diamond® bracket as a template, use a centering punch to mark hole center for the 1/2" bolt. Drill a 1/2" hole through the side of the factory track bar mount.

❑ [DIAGRAM 9] Locate the Black Diamond® track bar brace (#55-25-5704) as shown; note that the brace leg with the square-cut opening faces inboard. Insert the 9/16" x 3-1/4" bolt, and the 1/2" x 1" bolt, to properly locate the brace onto the axle tube. Do not install the bolts' attaching hardware; at this time, the bolts are being used to properly locate the brace prior to welding.

❑ [DIAGRAM 10] Mark the outside edges of the track bar brace where they make contact with the axle tube. Remove the brace then grind-off all paint, undercoating, etc., from the bracket-to-axle tube weld points.

27) WELD BRACE...

❑ Bolt the track bar brace to the track bar bracket / factory mount using the supplied 1/2" and 9/16" hardware; the supplied flat washers install on the nut sides. The supplied 1-1/4" OD x 1-5/8" sleeve is positioned inside the factory track bar mount, as per Diagram 9. Snug-up, but do not fully tighten this hardware.

DIAGRAM 7 - REAR TRACK BAR BRACKET INSTALLATION

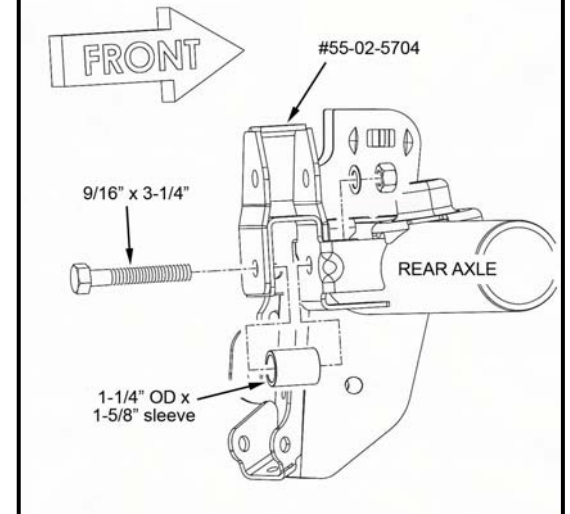
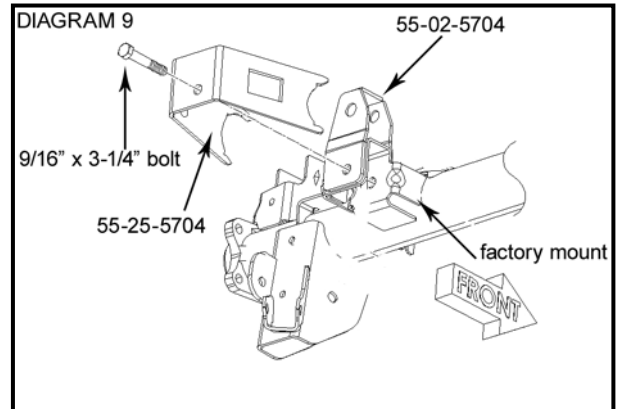
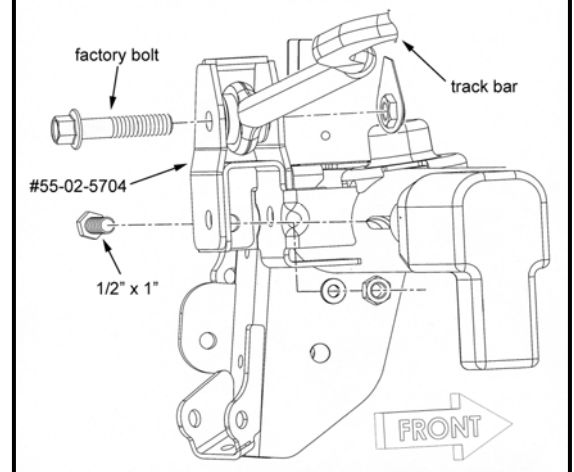

DIAGRAM 8 - TRACK BAR BRACKET



WARNING! To reduce the risk of fire / explosion, protect fuel lines and gas tank from sparks or flames with a fire blanket (preferably), or water saturated cloths.

[DIAGRAM 10] Tack all four corners of brace-to-axle tube then weld completely where shown.

CAUTION: To avoid warping the axle tube, weld approximately one inch at a time, and allow the axle tube to cool before resuming welding.

28) **PAINT TRACK BAR BRACE...** Once the area has cooled completely, mask-off or remove the track bar bracket then clean and paint all exposed metal. Tighten 1/2" hardware (75); tighten 9/16" hardware (105).

29) **RECONNECT TRACK BAR-TO-AXLE...** using the factory hardware. The bar is tightened in a later step.

30) BRAKE HOSE RELOCATION BRACKETS...

NOTE: If optional Bulletproof brake hoses are being used, these relocation brackets are not required.

Perform this step one side at a time.

A plastic clip, shown in Diagram 11, attaches the metal brake line to the frame; remove and discard this clip.

Attach the rear brake hose relocation bracket (#55-21-5704 driver side and #55-22-5704 passenger side) to the factory frame location using the factory hardware. Be sure the alignment tab engages with the hole in the frame, as shown. Tighten (95 in-lb).

Attach the brake hose-to-bracket using the supplied 1/4" x 3/4" bolt, washer, and Nyloc nut. Install bolt from the outside, place the washer on the nut side then tighten (95 in-lb).

[DIAGRAM 12] Carefully re-form the metal line so that it runs along the upper edge of the frame, as shown. The supplied Adel clamps (one per side) hold the re-formed metal brake lines snugly against the frame to prevent them from potentially making contact with the sway bar links.

31) PARKING BRAKE CABLES, 2-DOOR MODEL ONLY...

The parking brake cables are routed beneath the vehicle body (along the transmission tunnel), above a frame crossmember then down to each wheel. On each side,

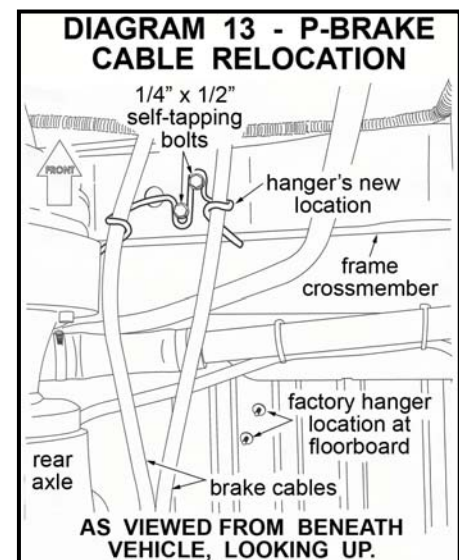
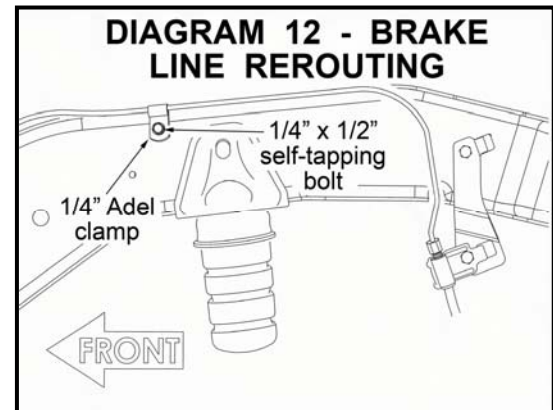
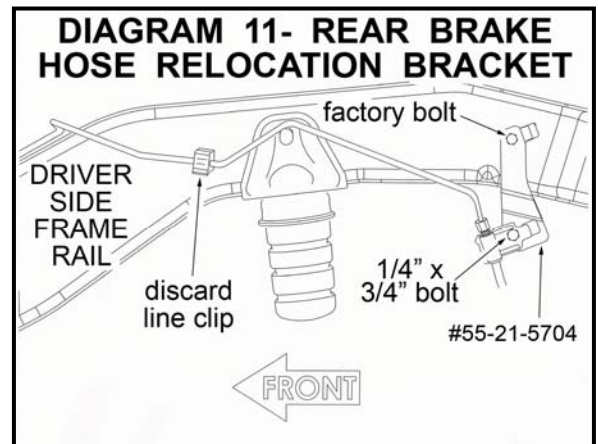
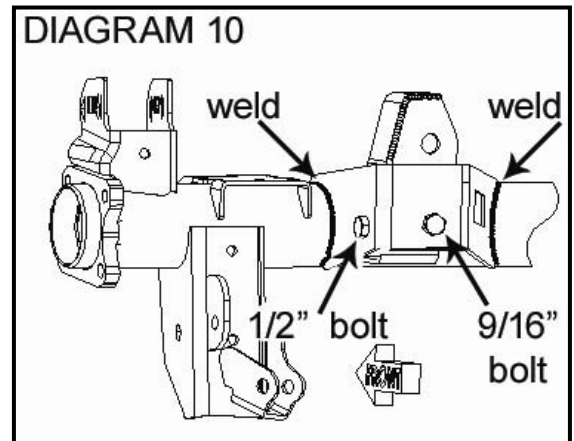

disconnect the cables at the axle and re-route them to below the frame crossmember. Reattach cables-to-axle.

32) PARKING BRAKE CABLES, 4- DOOR MODEL ONLY... [DIAGRAM 13]

The parking brake cables are routed beneath the vehicle body (along the transmission tunnel), above a frame crossmember, then through a wire hanger bracket that is attached to the floorboard. Detach the two parking brake cables from the wire hanger bracket then detach the wire hanger bracket from the floorboard.

Position the wire hanger bracket at the center of the frame crossmember, as shown. Using the wire hanger bracket as a template, mark the location for the two mounting holes to be drilled. Drill the mounting holes using a 13/64" bit. Attach the wire hanger bracket-to-frame crossmember using the supplied 1/4" x 1/2" self-tapping bolts and tighten (75 in-lb).

On each side, disconnect the parking brake cable at the axle and re-route them to below the frame crossmember. Insert each parking brake cable into the relocated wire hanger bracket then reconnect parking brake cables-to-axle.

33) STABILIZER BAR LINKS AND SHOCK ABSORBERS...[DIAGRAM 14]

Lubricate the supplied bushings and sleeves with a light, Silicone or Lithium based grease then install bushings / sleeves into the bottom (eyeing) end of the Black Diamond[®] stabilizer bar links (#716244).

Apply anti-seize to the top (stud) end of the Black Diamond[®] stabilizer bar links. Install the 1/2" jam nut onto the link then the 90° swivel end. Adjust the swivel end to reach a center of swivel-to-center of eye length of 11" then tighten the jam nut.

From the factory, the stabilizer bar links mount outboard of the anti-sway bar body with their upper studs facing inboard. The Black Diamond[®] links install opposite; mount them inboard of the stabilizer bar body with their upper studs facing up and outboard.

As shown, first position one 1/2" SAE washer onto the link stud then insert stud through the stabilizer bar body attachment hole. Position remaining 1/2" SAE washer, Nyloc nut and tighten (80).

Attach the Black Diamond[®] links' lower ends using the factory hardware. Tighten (75).

NOTE: The swivel links must be greased during each oil change / service.

34) SHOCK ABSORBERS (ordered separately)... Install shock hardware / boots. Install shocks using the factory bolts. At this time, tighten only the upper shock mount bolts (37). Apply shock decals.

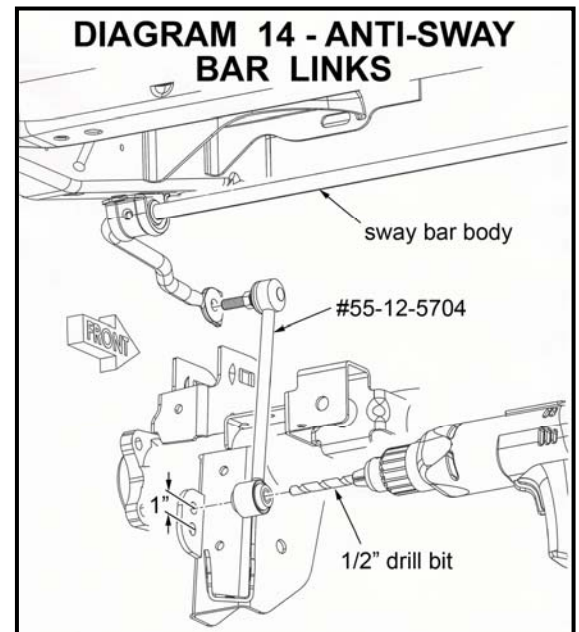

FINAL PROCEDURES

35) **TIRES / WHEELS...** Install the tires and wheels as per step 15.

36) **INITIAL CLEARANCE CHECK, REAR...** With the vehicle still on jack stands, and the suspension “hanging” at full extension travel, check all components for proper operation and clearances. Pay special attention to clearance between the tires / wheels and brake hoses, driveshaft, etc.

37) **HARDWARE TIGHTENING SEQUENCE...**

Remove jack stands and lower vehicle to the floor. The suspension is now supporting vehicle weight.

Rear track bar, both ends (125).

All rear link arms-to-frame and axle (125).

Front / lower link arms-to-frame and axle (125). **NOTE:** Be sure that eccentric cam bolts are positioned as per step 7.

Front / upper link arms-to-frame and axle (75).

All shock absorber eyes (56).

38) **FRONT TRACK BAR ADJUSTMENT...**

Verify that the tires (not the steering wheel) are pointed straight ahead. Position a plumb bob, or similar tool, against the inside edge of the frame. Measure the distance between the line of the plumb bob and the inside edge of the wheel. Record this measurement, then repeat the procedure on the other side.

Compare the two measurements; the goal is to make them equal. If the driver side measurement is greater than the passenger side, the track bar needs to be lengthened. If the passenger side measurement is greater than the driver side, the track bar needs to be shortened.

Disconnect the lower (Heim joint) end of the track bar from the axle and make the appropriate adjustments.

Tighten the Heim jam nut firmly then reattach the bar-to-axle (130). Tighten the bar-to-frame bolt (130).

WARNING! No more than 3/8” of Heim end threads can be exposed once the jam nut is tightened.

39) **CENTER THE STEERING WHEEL...**

IMPORTANT: The steering wheel must be centered prior to moving the vehicle, or an Electronic Stability Program sensor may be activated resulting in a dash light and a warning chime that requires 20 plus ignition key cycles to clear.

Start engine and steer wheels straight ahead. Loosen the nuts on the drag link adjustment sleeve then rotate adjuster until steering wheel center is achieved.

IMPORTANT - [DIAGRAM 14] Relay this information to the alignment shop: In order to achieve proper adjustment sleeve clamping force, clamp / bolt assemblies (found on the drag link and tie rod assemblies) must be positioned as shown. The open side of each clamp must align with the slot in the threaded adjustment sleeve. Improper positioning and bolt torque will promote linkage deflection, which may contribute to tire shimmy. Tighten clamp bolts (26).

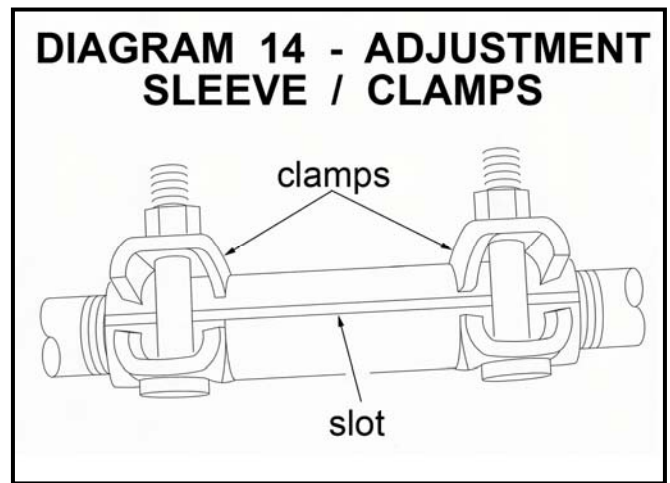

40) □ FINAL CLEARANCE and TORQUE

CHECK... Cycle steering lock-to-lock and inspect the tires / wheels, and the steering, suspension, and brake systems for proper operation, tightness and adequate clearance.

41) □ HEADLIGHTS... Readjust headlights to proper setting.

42) □ BLACK DIAMOND® WARNING DECAL... Install the WARNING TO DRIVER decal on the inside of the windshield, or on the dash, within driver's view. Refer below to: Important Product Use and Safety Information / Warnings.

43) □ ALIGNMENT... Realign vehicle to factory specifications. A precise alignment, including the centering of the steering wheel, is required in order for the vehicle's Electronic Stability Program to function properly. A laser alignment is recommended.

Limited Lifetime Warranty / Warnings

Your Superlift® product is covered by the Limited Warranty explained below that gives you specific legal rights. This limited warranty is the only warranty Superlift® makes in connection with your product purchase. Superlift® neither assumes nor authorizes any retailer or other person or entity to assume for it any other obligation or liability in connection with this product or limited warranty.

What is covered? Subject to the terms below, Superlift® will repair or replace its products found defective in materials or workmanship for so long as the original purchaser owns the vehicle on which the product was originally installed. Your warrantor is LKI Enterprises, Inc. d/b/a Superlift® Suspension Systems ("Superlift®").

What is not covered? Your Superlift® Limited Warranty does not cover products, parts or vehicles Superlift® determines to have been damaged by or subjected to:

- Alteration, modification or failure to maintain.
- Normal wear and tear (bushings, tie-rod ends, etc.). Scratches or defects in product finishes (powdercoating, plating, etc.),
- Damage to or resulting from vehicle's electronic stability system, related components or other vehicle systems.
- Racing or other vehicle competitions or contests. Accidents, impact by rocks, trees, obstacles or other aspects of the environment.

- Theft, vandalism or other intentional damage.

Remedy Limited to Repair / Replacement. The exclusive remedy provided hereunder shall, upon Superlift's inspection and at Superlift's option, be either repair or replacement of product or parts covered under this Limited Warranty. Customers requesting warranty consideration should contact Superlift® by phone (1-800-551-4955) to obtain a Returned Goods Authorization number. All removal, shipping and installation costs are customer's responsibility.

If a replacement part is needed before the Superlift® part in question can be returned, you must first purchase the replacement part. Then, if the part in question is deemed warrantable, you will be credited / refunded.

Other Limitations - Exclusion of Damages - Your Rights Under State Law

- Neither Superlift® nor your independent Superlift® dealer are responsible for any time loss, rental costs, or for any incidental, consequential or other damages you may have.
- This Limited Warranty gives you specific rights. You may also have other rights that vary from state to state. For example, while all implied warranties are disclaimed herein, any implied warranty required by law is limited to the terms of our Limited Lifetime Warranty as described above. Some states do not allow limitations of how long an implied warranty lasts and / or do not allow the exclusion or limitation of incidental or consequential damages, so the limitations and exclusions herein may not apply to you.

Important Product Use and Safety Information / Warnings

As a general rule, the taller a vehicle is, the easier it will roll over. Offset, as much as possible, what is lost in rollover resistance by increasing tire track width. In other words, go "wide" as you go "tall". Many sportsmen remove their mud tires after hunting season and install ones more appropriate for street driving; always use as wide a tire and wheel combination as feasible to enhance vehicle stability. We strongly recommend, because of rollover possibility, that the vehicle be equipped with a functional roll bar and cage system. Seat belts and shoulder harnesses should be worn at all times. Avoid situations where a side rollover may occur.

Generally, braking performance and capabilities are decreased when significantly larger / heavier tires and wheels are used. Take this into consideration while driving. Also, changing axle gear ratios or using tires that are taller or shorter than factory height will cause an erroneous speedometer reading. On vehicles equipped with an electronic speedometer, the speed signal impacts other important functions as well. Speedometer recalibration for both mechanical and electronic types is highly recommended.

Do not add, alter, or fabricate any factory or aftermarket parts to increase vehicle height over the intended height of the Superlift® product purchased. Mixing component brands is not recommended.